



RANGE OF PERFORMANCE

Flow rate up to 50 l/min (3 m³/h)
Head up to 90 m

LIMITS OF USE

Manometric suction height up to 8 m
Liquid temperature up to + 90°C
Environment temperature up to + 40°C

EXECUTION AND SAFETY STANDARDS

EN 60034-1
IEC 34-1
CEI 2-3



USES AND INSTALLATIONS

They are recommended for pumping clean water without abrasive particles and liquids that are chemically non aggressive for the materials of which the pump is made. **MADE OF HIGH-PERFORMANCE TECHNO-POLYMER WITH FRONT COVERS ON THE BRASS IMPELLERS; THIS OFFERS A SURE GUARANTEE AGAINST RUST AND OXIDATION. DUE TO THESE CHARACTERISTICS THEY ARE RECOMMENDED FOR USE IN THE INDUSTRIAL SECTOR, FOR EXAMPLE COOLING, CONDITIONING, IRONING SYSTEMS, ETC.** The pumps must be installed in enclosed places, or at least protected against inclement weather.

GUARANTEE 2 YEARS according to our general terms of sale.

CONSTRUCTION CHARACTERISTICS

- **PUMP BODY:** high-performance technopolymer, with threaded metal insert ISO 228/1, inserted in the inlets, allowing a sure connection of the pipes without damaging the pump body.
- **PUMP BODY COVER:** brass .
- **LANTERN (patent n° 1289150):** aluminium with front shim disk in brass; eliminates blockage of the impeller after long periods of inactivity.
- **IMPELLER:** brass, of the type with radial peripheral vanes.
- **MOTOR SHAFT:** stainless steel EN 10088-3 - 1.4104.
- **MECHANICAL SEAL:** ceramic - graphite - NBR.
- **ELECTRIC MOTOR:** the pumps are coupled to a PEDROLLO electric motor with specially calculated dimensions, silent-running, closed, with external ventilation, suitable for continuous duty.
PQAm: single-phase 230 V - 50 Hz with condenser and thermal overload protector built into the winding.

PQA: three-phase 230/400 V - 50 Hz.

- **INSULATION:** class F.
- **PROTECTION:** IP 44.
- **REGISTERED MODEL**

EXECUTIONS ON REQUEST

- ⇒ pump shaft in stainless steel EN 10088-3 - 1.4401 (AISI 316)
- ⇒ special mechanical seal
- ⇒ protection IP 55
- ⇒ other voltages or frequency 60 Hz

CURVES AND PERFORMANCE DATA AT n= 2900 1/min

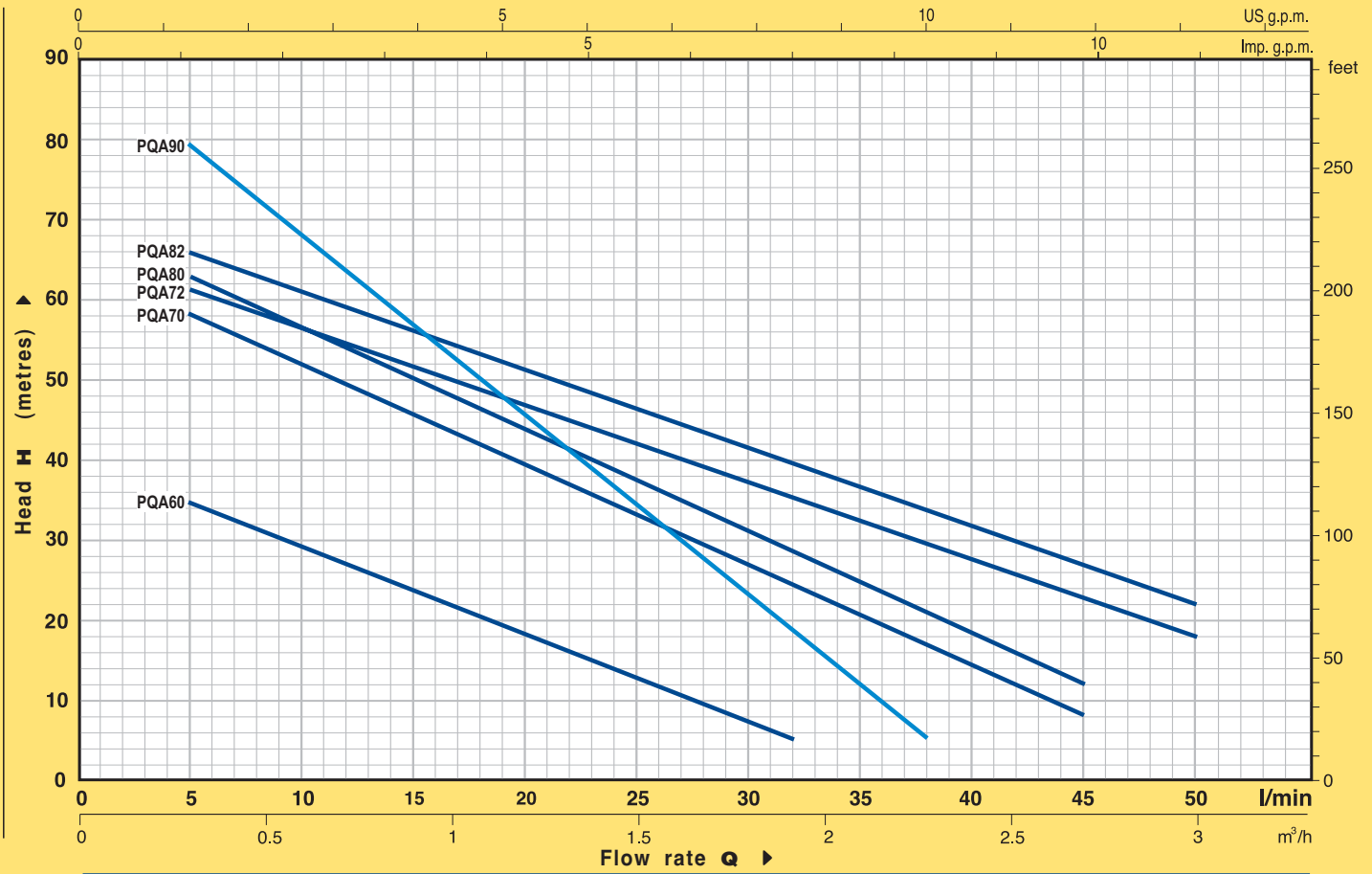

TYPE		POWER		Q	H metres													
Single-phase	Three-phase	MW	HP		m³/h	0	0.1	0.3	0.6	0.9	1.2	1.5	1.8	1.9	2.3	2.7	3.0	
				l/min	0	2	5	10	15	20	25	30	32	38	45	50		
PQAm 60	PQA 60	0.37	0.50	H metres	40	38	35	29	23.5	18	12.5	7	5					
PQAm 70	PQA 70	0.55	0.75		65	62	58	52	45.5	39.5	33	27	24	16.5	8			
PQAm 72	PQA 72	0.55	0.75		65	-	62	57	52	47	42	37.5	35.5	29.5	22.5	18		
PQAm 80	PQA 80	0.75	1		70	66	62	56	49.5	43	37	31	28	20.5	12			
PQAm 82	PQA 82	0.75	1		70	-	66	61	56	51	46	41.5	39.5	37.5	26.5	22		
PQAm 90	PQA 90	0.75	1		90	86	79	68	56.5	45.5	34	23	18.5	5				

Q = Flow rate H = Total manometric head

Tolerance of the performance curves according to EN ISO 9906 App. A.

DIMENSIONS AND WEIGHTS

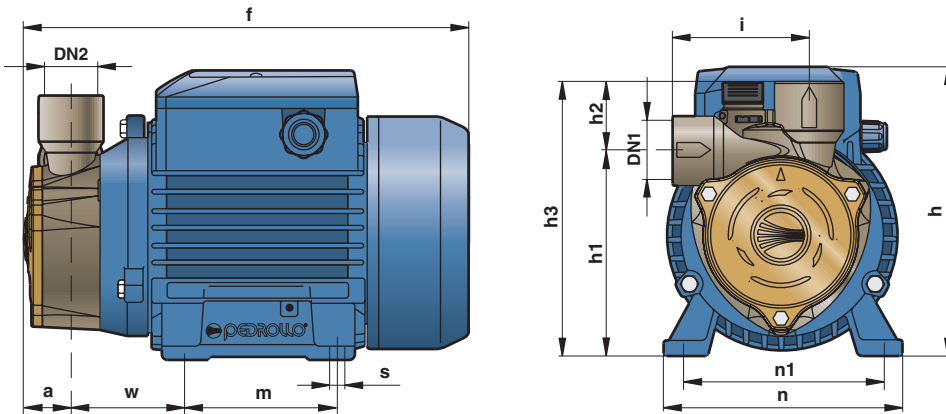

TYPE		INLETS		DIMENSIONS mm													kg	
Single-phase	Three-phase	DN1	DN2	a	f	h	h1	h2	h3	i	m	n	n1	w	s	1~	3~	
PQAm 60	PQA 60	1/2"	1/2"	25	226	152	103	33	136	72.5	80	120	100	55	7	4.8	4.8	
PQAm 70	PQA 70	1/2"	1/2"	28	258	179	116.5	32.5	149		83	90	138	112		62	10.3	9.3
PQAm 72	PQA 72	1"	1"				121	30	151	83	10.4						9.4	
PQAm 80	PQA 80	1/2"	1/2"	27	257	121	116.5	32.5	149	72.5	90	138	112	62		7	10.5	9.5
PQAm 82	PQA 82	1"	1"				30	151	83									
PQAm 90	PQA 90	1/2"	1/2"				121	35	156	76								